

Flammable and Acid Storage Cabinets; Vacuum Pump Cabinet

The Flammable Liquid Storage Cabinet is a "cabinet-within-a-cabinet" design with fully welded 18ga interior and exterior units. Both cabinets are completely powder coated inside and out, offering greater protection against corrosion than the standard double panel construction. This design creates a 1.5" airspace on all four sides as well as top and bottom for heat resistance up to 2400 degrees F.

The interior of the cabinet contains one fully adjustable shelf and a 2" deep removable drip pan to capture any spills or leaks inside the cabinet. Exterior depth of the cabinet is 18" and interior depth is 14". A 2" x 2" 12ga support angle is shipped with each cabinet for countertop installation.

Doors have a continuous hinge and lever type handles with a hidden 3-point lock mechanism. If a self-closing feature is required, a hydraulic closure will be attached to the doors and a custom closing system attached to the interior cabinet. The back of the cabinet has two venting holes that are plugged with 2" barrel bungs.

AMS Flammable Liquid Storage Cabinets are constructed in accordance with OSHA and NFPA 30, and are UL listed.

Flammable Storage Cabinet

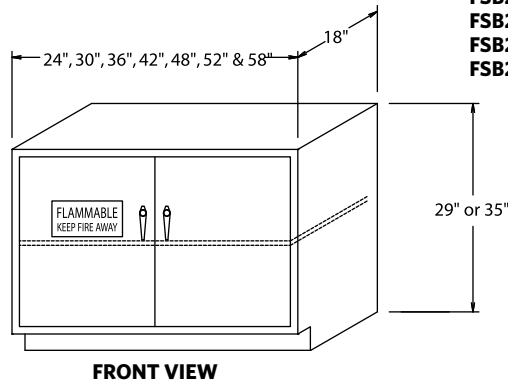

- FSB2924-100
- FSB2930-200
- FSB2936-200
- FSB2942-200
- FSB2948-200
- FSB2952-200
- FSB2958-200

- FSB3524-100 } 1 Door Units
- FSB3530-200
- FSB3536-200
- FSB3542-200
- FSB3548-200
- FSB3552-200
- FSB3558-200

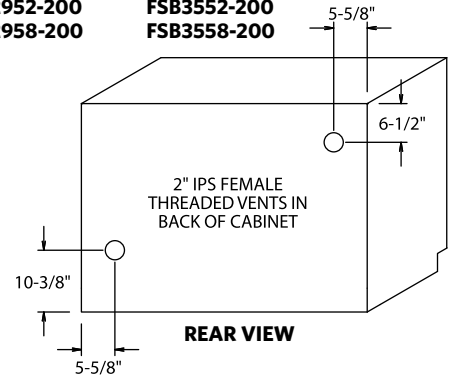

Flammable storage cabinets can be painted any standard color or safety yellow. For synchronized self-closing doors, add -SCC to the part number. For 22" deep, replace -200 with -220. For mobile cabinet, contact your AMS representative.

Acid Storage Cabinet

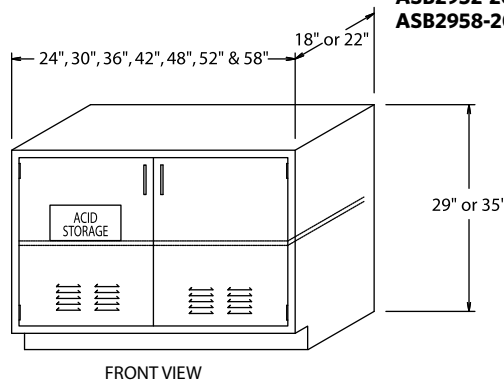

- ASB2918-100
- ASB2924-100
- ASB2930-200
- ASB2936-200
- ASB2942-200
- ASB2948-200
- ASB2952-200
- ASB2958-200

- ASB3518-100 } 1 Door Units
 - ASB3524-100
 - ASB3530-200
 - ASB3536-200
 - ASB3542-200
 - ASB3548-200
 - ASB3552-200
 - ASB3558-200
- Add Suffix "VK" if Vent Kit is Required**

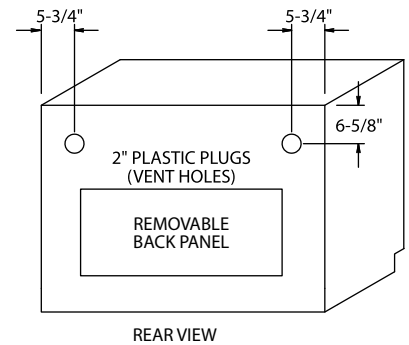

Acid cabinet can be painted any standard color or safety blue.

Vacuum Pump Cabinet

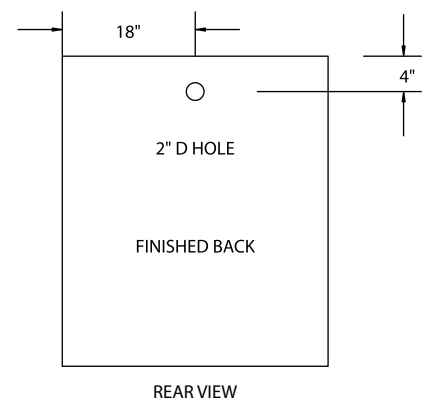
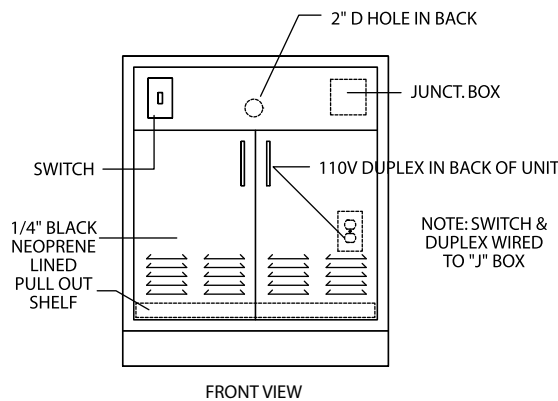

Additional insulation materials for noise reduction available upon request.